



**JABATAN LAUT MALAYSIA**

MARINE DEPARTMENT MALAYSIA

Ibu Pejabat Laut, Peti Surat 12, 42007 Pelabuhan Klang

Tel : 03-33467777, Fax : 03-31685289, E-mail : [kpgr@marine.gov.my](mailto:kpgr@marine.gov.my)

Webpage : <http://www.marine.gov.my>

**NOTIS PERKAPALAN MALAYSIA**  
*MALYSIAN SHIPPING NOTICE*

**NPM** 04/2016

**MSN** 04/2016

---

Notis kepada pemilik kapal, agen perkapalan, nakhoda, pelaut, pengusaha pelabuhan dan industri maritim  
*Notice to shipowners, ship agents, masters, seafarers, port operators and the maritime industry*

---

**GARISPANDUAN BERHUBUNG PEMBINAAN PELAMPUNG PANDU JENIS KELULI.**

**GUIDELINES ON THE CONSTRUCTION OF STEEL NAVIGATIONAL LIGHTBUOYS.**

---

Notis ini memberi maklumat bahawa untuk menyeragamkan jenis dan saiz pelampung pandu yang digunakan dipelabuhan Malaysia, satu garis panduan telah disediakan oleh Jabatan Laut Malaysia untuk digunapakai oleh semua pihak berkaitan. Sebarang percanggahan perlulah dirujuk kepada Ketua Pengarah Laut Malaysia untuk penilaian.

Bersama-sama ini disertakan **GUIDELINES ON THE CONSTRUCTION OF STEEL NAVIGATIONAL LIGHTBUOYS** bertarikh 1 Mac 2016.

This notice serves to inform that in order to standardise the type and size of navigational lightbuoys to be used in the waters of Malaysia, the Marine Department of Malaysia has produced a guideline pertaining to this. It should be used as a guideline by all parties and any diversion from it shall be referred to the Director General of Marine Malaysia for evaluation.

Enclosed herewith is the **GUIDELINES ON THE CONSTRUCTION OF STEEL NAVIGATIONAL LIGHTBUOYS** dated 1<sup>st</sup> March 2016

**(Dato' Haji Baharin bin Dato' Abdul Hamid)**

Ketua Pengarah Laut / Director General of Marine

Tarikh : 1 MAC 2016



**Marine Department Malaysia**

# **GUIDELINES ON THE CONSTRUCTION OF STEEL NAVIGATIONAL LIGHTBUOYS**

1 March 2016

# Document Revisions

Revisions to the document are to be noted in the table prior to the issue of a revised document.

<b>Date</b>	<b>Page/Section Revised</b>	<b>Reason for revision</b>

# **GUIDELINES ON THE CONSTRUCTION OF STEEL NAVIGATIONAL LIGHTBUOYS**

## **1.0 General**

- 1.1 Recognising the need to provide guidance on the type and size of Navigational Lightbuoys to be used in Malaysian waters, the Marine Department Malaysia has produced a guideline on it.
- 1.2 The standardisation in the type, size and design of the lightbuoy is made after taking into account the operational suitability, handling, stability, design life, economics, spares and disposals.

## **2.0 Design**

- 2.1 The design of the navigational lightbuoy shall be as in Drawing I.
- 2.2 The buoys are to be fitted, where applicable, navigational marks in accordance with the IALA Buoyage System.
- 2.3 Fabrication of the buoys shall be carried out in Malaysia.

## **3.0 Basic Requirements**

- 3.1 Diameter of buoy body and dish plate shall be 3000 mm.
- 3.2 Total height of buoy shall be 5300 mm
- 3.3 Height of the trestle from bottom of light base plate to the top of upper dish plate shall be 2560 mm.
- 3.4 The buoy shall have ample stability and sufficient freeboard.

## **4.0 BUOYANCY CHAMBER**

- 4.1 Marine mild steel plates of ABS (American Bureau of Shipping) Classification Ship Plate Grade A or equivalent shall be used for fabrication of buoyancy chamber.

- 4.2 The thickness of plates used for the respective buoyancy chamber's components shall be as follows:
  - 4.2.1 Buoy body - minimum 9 mm.
  - 4.2.2 Bulkhead - minimum 9 mm
  - 4.2.3 Dish plate - minimum 12mm.
  - 4.2.4 Stiffener - minimum 9 mm.
- 4.3 Depth of buoy body and dish plates shall be at least 1300 mm. and 375 mm. respectively. The shape and sizes of dish plates shall be identical to the Drawing II.
- 4.4 The buoyancy chamber shall be divided into two (2) watertight compartments with each compartment having its own manhole as specified in paragraph 7.0. Each buoyancy chamber shall be strengthened by three (3) vertical stiffeners spaced at regular intervals.
- 4.5 For record, Mill Test Certificate of the materials used in which data on the chemical composition and physical properties stated shall be kept. It shall be duly endorsed by local Ship Classification Society or Government Standards Authority.

## 5.0 SKIRT

- 5.1 The skirt as in Drawing II shall be fabricated from marine mild steel plates of minimum 9 mm. thickness ABS Classification Grade A or equivalent.
- 5.2 A skirt ring shall be provided at the bottom of the skirt for ease of movement of the buoy on the ship's deck.
- 5.3 Eight (8) holes of 35 mm. diameter equispaced around the skirt shall be provided for air release.
- 5.4 Skirt height shall be at least 690 mm. from the bottom of lower dish plate to buoy base. Skirt outer diameter shall be at least 1800mm.

## 6.0 COUNTERWEIGHTS

- 6.1 At least eight (8) number of cast iron counterweight segments each of 100 kgs. weight shall be fixed equispaced inside the skirt to attain stability of the buoy.
- 6.2 Galvanised bolts and nuts of size DIN (Deutsches Institut für Normung) M30 shall be used to fasten the counterweight segments.

## 7.0 MANHOLE

- 7.1 The manhole shall have a minimum opening of 585 mm. and placed according to Drawing III.
- 7.2 The manhole cover shall be fitted to the opening by using sixteen (16) number of stainless steel SUS316 studs and nuts size DIN M20.
- 7.3 Neoprene rubber gasket of at least 5 mm. thickness shall be used for water tightness of the manhole.
- 7.4 An access for pressure test shall be provided on each manhole cover. The access shall be fitted with socket and stainless steel SUS 316 plug of M20 size.

## 8.0 LIFTING AND MOORING EYES

- 8.1 Each buoy shall be fitted with four (4) lifting eyes and two (2) mooring eyes as shown in Drawing IV.
- 8.2 Internal diameter and thickness of each eye shall be 110 mm. and 60 mm. respectively. The eyes shall be made from cast steel. The standard and grade of the cast steel shall be stipulated.
- 8.3 To prevent the mooring eyes from wear and tear, the inner part shall be welded with stainless steel SUS 316 doubler plate.

## 9.0 BATTERY BOX BASE PLATE

- 9.1 Four (4) battery box base plate brackets as shown in Drawing II shall be welded on top of the upper dish plate. The base plate shall be made of marine mild steel angle bar 100 mm. x 100 mm. x 10 mm.

## 10.0 BUOY SERIAL NUMBERS

- 10.1 The buoy serial numbers as in Drawing II shall also be welded on the buoy dish end and to start with A/1501.

Indications : A – 3.00 m dia.size  
15 – Year of fabrication (2015)  
01- Serial number

- 10.2 The ownership mark of the buoy shall also be welded on the same surface.

## 11.0 TRESTLE SHOES

- 11.1 Trestle shoes as shown in Drawing V shall be welded on the upper dish plate as in Drawing I.

- 11.2 A channel shall be provided at the corner of the trestle shoes to drain out trapped water.

- 11.3 Stainless steel size DIN M20 bolts & nuts shall be used to secure trestle legs onto the trestle shoes

## 12.0 TRESTLE

- 12.1 Trestle shall be constructed as shown in Drawing I.

- 12.2 Trestle and its components shall be constructed of marine grade mild steel unless otherwise stated.

- 12.3 Trestle shall be secured to buoy body through trestle shoes.

- 12.4 Horizontal and vertical beams of the trestle shall be constructed of angle bar at least 50mm. x 50mm x 6mm.
- 12.5 Top mark base plate as shown in Drawing V shall be provided to secure Topmarks of different shapes as shown in Drawing VI.
- 12.6 Man guard rail of at least 1500 mm. outer diameter and guard stay secured on top of trestle at the level of the lantern base. The man guard rail shall be made of pipe having 50 mm. diameter and 12 mm. thickness.
- 12.7 The lantern base at the top of the trestle as shown in Drawing V shall be provided with holes for securing the lantern and Topmark. The material used shall be marine plate of 10 mm. thickness
- 12.8 Buoy name plates shall be constructed of 10 mm. thick plate. These plates shall be welded onto the trestle legs on three sides.
- 12.9 Horizontal beam shall be welded behind the top part of the name plate as to form the foot rest.
- 12.10 Four (4) stainless steel SUS316 stud and nut of M 8 size and 15 mm. length shall be welded at each corner of the name base plate and 30 mm. for all edges.
- 12.11 The inner part of each trestle legs shall be welded with plate of 20mm. x 5 mm. thick at each level of the climbing steps as to provide a passage for cable.

### 13.0 STUDS/BOLT& NUTS

- 13.1 All studs/bolts and nuts used in the fabrication of the buoys and their accessories shall be of stainless steel SUS 316 and size DIN (Deutsches Institute fuer Normung) M20 unless otherwise stated.

### 14.0 NAVIGATIONAL MARKS

- 14.1 Navigational marks of the buoys shall be in accordance with



IALA Buoyage System for Region A.

- 14.2 Topmarks shall be made of polyethylene with aluminium frame and its size shall be in accordance with IALA guidelines.

15.0 PAINTING

- 15.1 All buoys shall be coated with marine paints.

- 15.2 Generally, the painting scheme applied shall be as follows:

Below Water Level

Primer

two pack epoxy coating reinforced with glass flake

Above Water Level

Primer

two pack epoxy coating reinforced with glass flake

Final coat

polyurethane fluorescence with clear UV protective coating.

- 15.3 For painting purposes water level mark is 300 mm. above the freeboard water level of the buoy.
- 15.4 Number of coatings and value of dry film thickness shall be recommended by the paint manufacturer as the paint shall protect the buoys for a period of more than two (2) years. The paint scheme shall be as recommended and certified by the paint manufacturer.
- 15.5 The paint shall be applied strictly in accordance to the recommendations and guidance by the paint manufacturer.

16.0 CATHODIC PROTECTION

- 16.1 The surface areas below the waterline of the buoy shall be

protected by means of cathodic protection using adequate numbers of aluminum anode.

## 17.0 TESTING OF BUOY

17.1 All the buoys must undergo the following tests :

i. Air Tightness Test

- The buoyancy chamber of each buoy shall be air pressured to 0.3 kg/cm.sq. and the chamber shall hold that pressure for at least ten minutes.
- The buoyancy chamber is then to be checked for signs of air leakage if any by using foam.

Buoyancy and Satbility Test

The buoy shall be put into water to determine the following:

- Height of freeboard in mm.
- Freeboard water level.
- Natural period in second
- 3 person shall be put on the buoy to assess its performance
- Draft with 1500 Kg mooring load

## 18.0 MOORINGS

18.1 Adequate length of moorings shall be used. It shall comprise of the followings :

- i. Swivel
- ii. Schackle
- iii. Open linked chain
- iv. 5 ton concrete sinker

## 19.0 LIGHTING EQUIPMENT

- 19.1 Only lighting equipment that meets the specifications of the Marine Department shall be used.
- 19.2 The light characters shall be approved by the Marine Department
- 19.3 The light shall be of not less than 75 candelas in effective intensity with a minimum vertical divergence of 9 degrees and with a minimum ON time of 0.4 seconds.

Effective Intensity Calculation :-

$$I_e = \frac{J}{C + \frac{J}{I_o}}$$
$$J = \int_0^t I(t) dt \Rightarrow J = I_o t$$
$$I_e = \frac{I_o t}{C + \frac{I_o t}{I_o}} = \frac{I_o t}{C + t}$$

- where:  $I_e$  = effective intensity (candelas)
- $J$  = integrated intensity of the flash (candela.seconds)
- $I_o$  = the maximum intensity during the flash interval (candelas)
- $C$  = a visual time constant, taken to be 0.2 seconds for night-time observation

- 19.4 In areas with strong background lighting, the Marine Department shall stipulate the minimum effective intensity for the light on individual basis.
- 19.5 The period of autonomy in the power sizing for the lighting equipment shall be 7 days. Where self-contained lights are to be used, it is only allowed for lights with duty cycle of not more than 30%.

DRAWINGS  
I-VI

# Drawing I

## LIGHTBUOY DRAWING

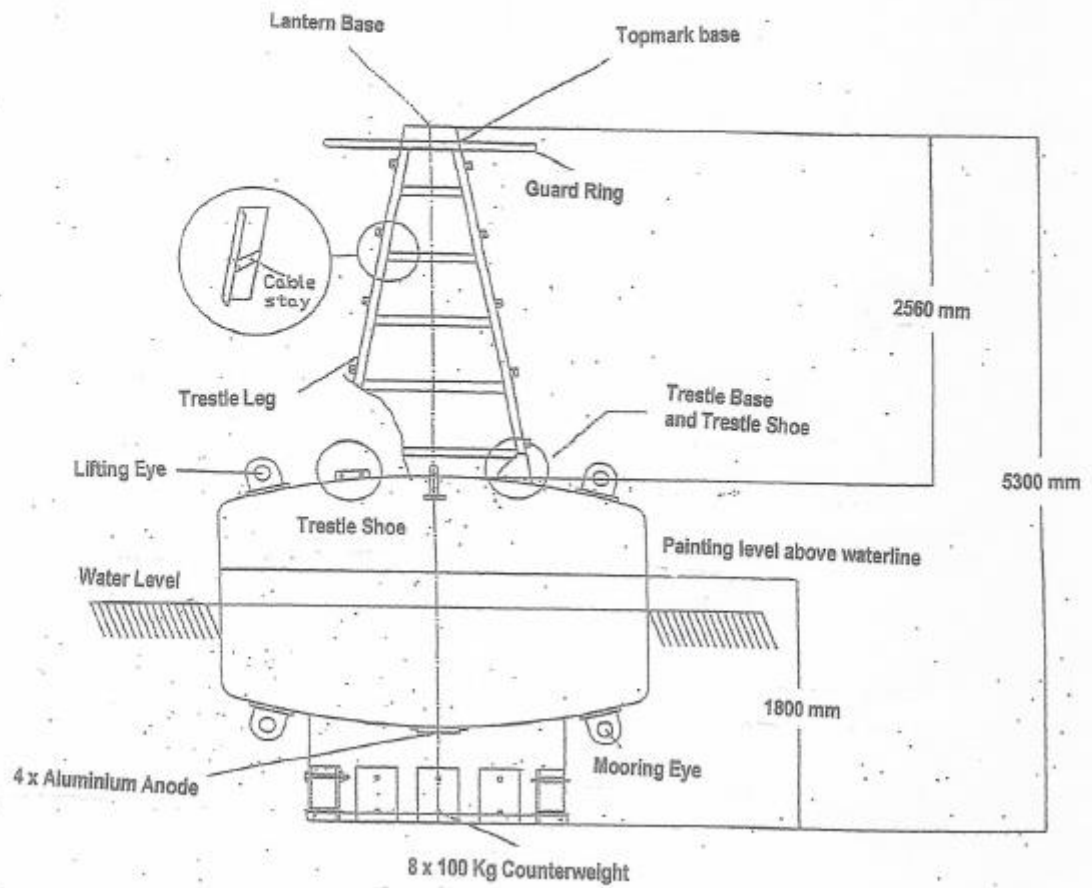



# MANHOLE

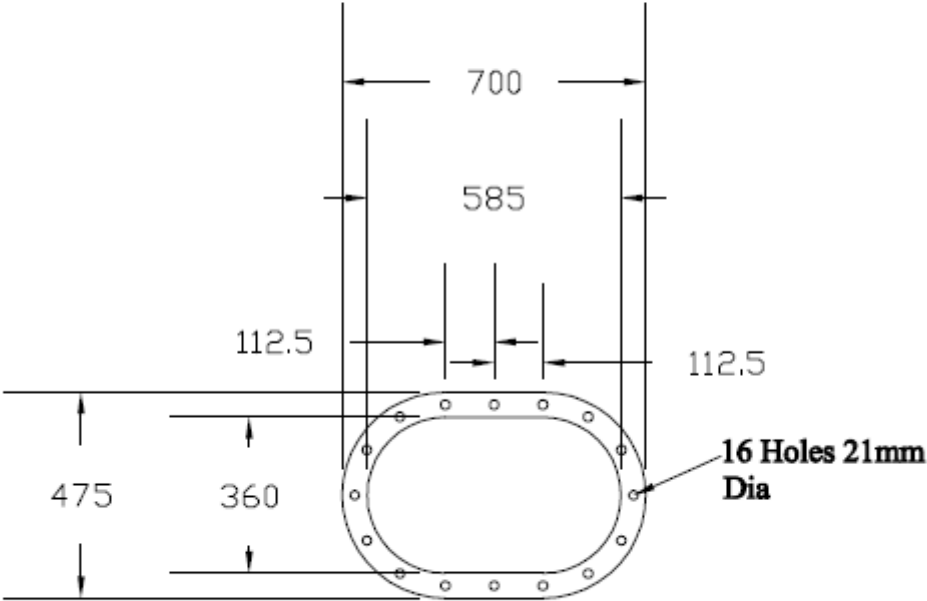

**Manhole Rubber Gasket (5mm Thickness)**

### MOORING EYE

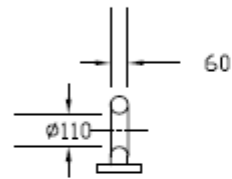
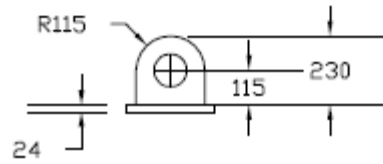
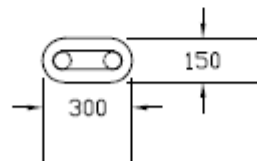
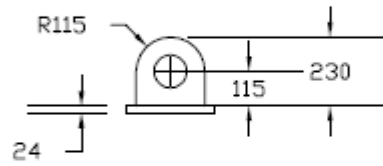
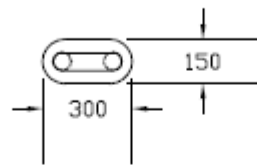

### LIFTING EYE

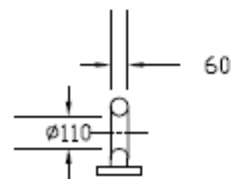

### MOORING EYE



# Buoy Trestle

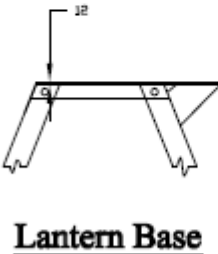
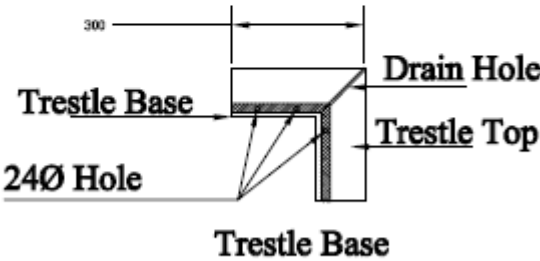
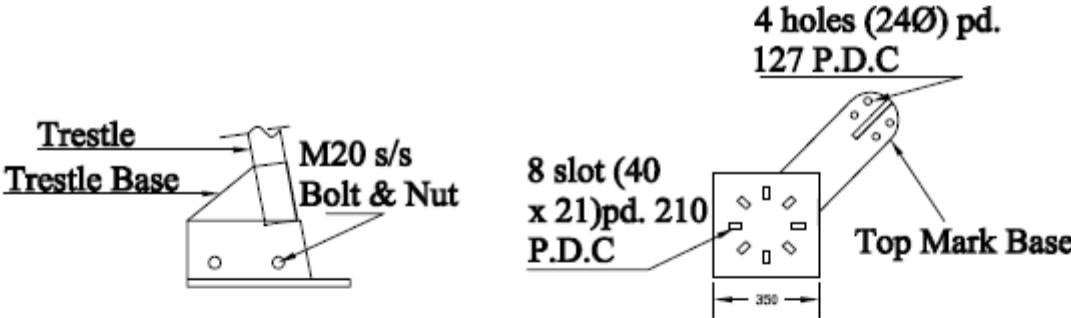
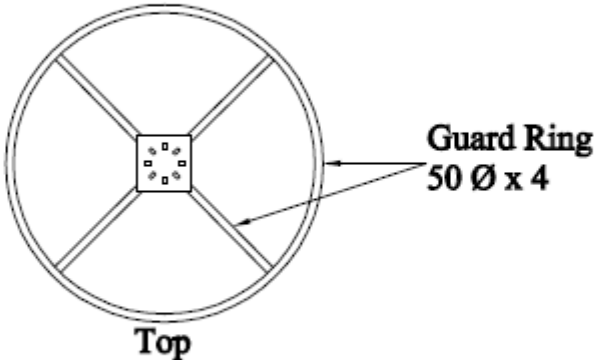

### Light Buoy Type of Top Mark

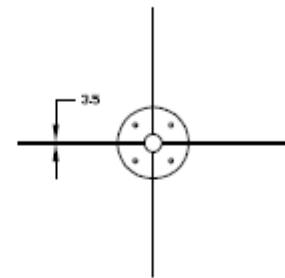
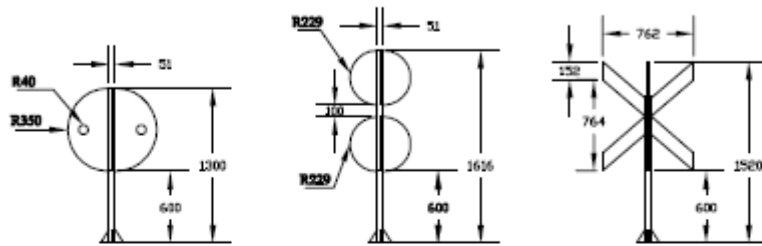

Top view for all Top Mark Type

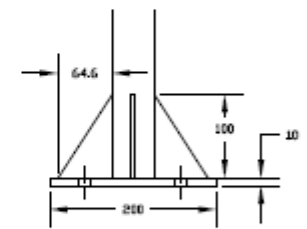
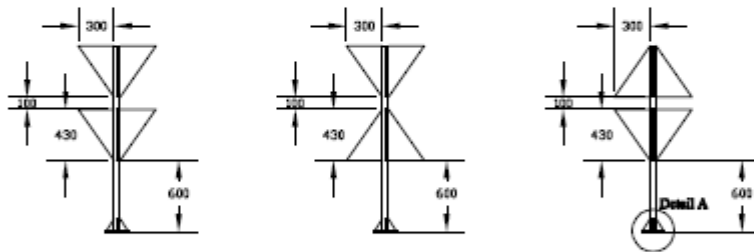

Detail A Front view of Top Mark Base

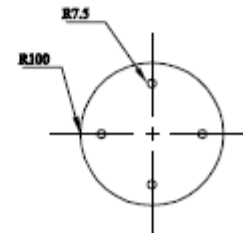
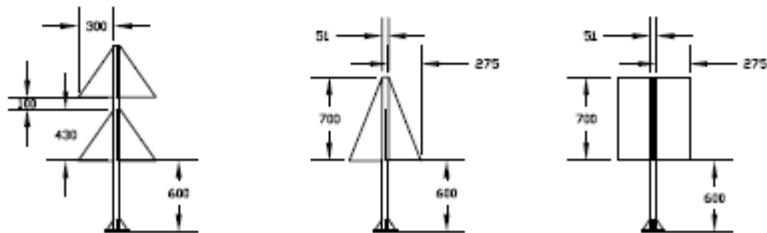

Bottom view of Top Mark Base